

**ORBOT<sup>®</sup>**  
**SLim**  
LITHIUM-ION HYBRID



**OPERATING MANUAL**

**CE**

# WARRANTY

All ORBOT equipment has been carefully tested and inspected at our USA factory. ORBOT SLiM machines are guaranteed for one year from the date of original purchase against defects or workmanship made during manufacture. Within the guarantee period we undertake at our discretion, to repair or replace any part found to be defective, free of charge to the purchaser **with subject to the following conditions:**

Claims made under the terms of the guarantee must be supported by the original invoice issued at the time of sale along with the machine serial number.

For claims under this guarantee contact the supplier from whom you've purchased the product who will arrange the appropriate action. Do not initially return the product as this could lead to transit damage.

Neither ORBOT nor its distributors will be held responsible for any incidental or consequential loss.

### ***This guarantee does not cover:***

- Periodic maintenance, repair or replacement of parts due to normal wear and tear.
  - Damage caused by accident, misuse or neglect, fire or the fitting of other than genuine ORBOT parts.
  - Defects in other than genuine ORBOT parts, repairs, modifications or adjustments made by other than an ORBOT service engineer or authorized service dealer.
  - Costs and risks of transport relating directly or indirectly to the guarantee of this product.
  - Consumable items such as brushes, drivers, velcro discs, gliders, pads and so forth.
- ORBOT has a policy of continual product development and we reserve the right to alter specifications without prior notice.

## MACHINE DATA

Model:	_____
Serial:	_____
Date of Purchase:	_____
Dealer:	_____
Address:	_____
Phone Number:	_____
Sales Representative:	_____

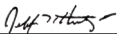
<b>EC Declaration of Conformity</b>	<b>CE</b>
<b>Machine Type:</b> Floor <b>Model:</b> Orbot Sprayborg	
This Machine is in conformity with the following EU directives:	
- Machinery Directive: 2006/42/EC	
- Electro Magnetic Compatibility Directive: 2004/108/EC	
- In conformity with 2006/95/EC	
<b>Applied harmonized standards:</b> EN 60335-1, EN 60335-2-67	
<b>HOS GmbH</b> Hruby Orbital Systems Kleiststraße 7, 10787 Berlin Date: 02/08/2010	 _____ Jeffrey Hruby CEO

<b>Warranty</b>	<b>2</b>
EC Declaration of Conformity	
<b>How to Use This Manual</b>	<b>4</b>
<b>Safety - Important Instructions</b>	<b>5 - 7</b>
<b>Technical Details</b>	<b>8</b>
<b>Operation</b>	<b>9 - 16</b>
Unpacking	<b>9</b>
Solution Tank	
Pad/Brushes	
Power Switch	
Battery	
Handle Position	<b>10</b>
Operating Machine / Operating Option	
Spray System	
Lifting and Handling	<b>11</b>
Storage	
Accessories and Applications	
Pad Driver	
SuperZorb Pad	<b>12</b>
MicroFiber Pad	
UltraLift Pad	
AkwaStrip Pad	
StoneFlash Pad	<b>13</b>
Carpet Brush	
Tile & Grout Brush	
<b>Maintenance</b>	<b>14</b>
Cleaning the Machine	
Checking the Machine	
SLiM Cleans in Small Spaces	
<b>Part Diagrams and Part Lists</b>	<b>15 - 22</b>
<b>Wiring Diagram</b>	<b>23</b>

# HOW TO USE THIS MANUAL

This manual contains the following sections:

- How to Use This Manual
- Safety
- Operations
- Maintenance
- Parts List

The HOW TO USE THIS MANUAL section will tell you how to find important information for ordering correct repair parts.

Parts may be ordered from authorized dealers. When placing an order for parts, the machine model and machine serial number are important. Refer to the MACHINE DATA box which is filled out during the installation of your machine. The MACHINE DATA box is located on the inside of the front cover of this manual.

The model and serial number of your machine is located on the left side of the handle, from the operators perspective.

The SAFETY section contains important information regarding hazardous or unsafe practices of the machine. Levels of hazards are identified that could result in product damage, personal injury, or severe injury resulting in death.

The OPERATIONS section is to familiarize the operator with the operation and function of the machine.

The MAINTENANCE section contains preventive maintenance to keep the machine and its components in good working condition. They are listed in this general order:

- Storage
- Maintenance
- Troubleshooting

The PARTS LIST section contains assembled parts illustrations and corresponding parts list. The parts lists include a number of columns of information:

- REF – column refers to the reference number on the parts illustration.
- PART NO. – column lists the part number for the part.
- PRV NO. – reference number.
- QTY – column lists the quantity of the part used in that area of the machine.
- DESCRIPTION – column is a brief description of the part.
- SERIAL NO. FROM – If this column has an (\*) and a Reference number, see the SERIAL NUMBERS page in the back of your manual. If column has two asterisk (\*\*), call manufacturer for serial number. The serial number indicates the first machine the part number is applicable to. The main illustration shows the most current design of the machine. When a boxed illustration is shown, it displays the older design.
- NOTES – column for information not noted by the other columns.

**NOTE:** If a service or option kit is installed on your machine, be sure to keep the KIT INSTRUCTIONS which came with the kit. It contains replacement parts numbers needed for ordering future parts.

**NOTE:** The manual part number is located on the lower left corner of the front cover.

## IMPORTANT SAFETY INSTRUCTIONS

When using this machine, basic precautions must always be followed, including the following:

### READ ALL INSTRUCTIONS BEFORE USING THIS MACHINE.

## WARNING

### To reduce the risk of fire, electric shock, or injury:

- Use only indoors. Do not use outdoors or expose to rain.
- Use only as described in this manual. Use only manufacturers recommended components and attachments.
- If the machine is not working properly, has been dropped, damaged, left outdoors, or dropped into water, return it to an authorized service center.
- Do not operate the machine with any openings blocked. Keep openings free of debris that may reduce airflow.
- Machine can cause a fire when operating near flammable vapors or materials. Do not operate this machine near flammable fluids, dust or vapors.
- This machine is suitable for commercial use such as: in hotels, schools, hospitals, factories, shops, and offices for more than normal housekeeping purposes.
- Maintenance and repairs must be done by qualified personnel.
- During operation, use caution around other persons, especially children.
- The machine shall only be operated by instructed and authorized persons.
- When leaving unattended, unplug the machine.
- Do not handle the plug or machine with wet hands.
- Do not unplug machine by pulling on cord. To unplug, grasp the plug and not the cord.
- Do not use with damaged cord or plug. Follow all instructions in this manual concerning grounding the machine.
- Do not pull or carry by cord, use cord as a handle, close a door on cord, or pull cord around sharp edges or corners.
- Do not pull/run machine over cord. Keep cord away from heated surfaces.
- Connect to a properly grounded outlet. See Grounding Instructions.
- If the supply cord is damaged it must be replaced by an authorized service agent.
- Unplug before cleaning or servicing.
- Operational hazard may occur when running the machine over the supply cord.
- This appliance has been designed for use with pads specified by the manufacturer. The fitting of other pads may affect its safety.
- This machine is for dry use only and shall not be used or stored outdoors in wet conditions
- Moving Parts - To reduce the risk of injury, unplug before servicing.

### READ AND SAVE THESE INSTRUCTIONS

# SAFETY

The following symbols are used throughout this guide as indicated in their descriptions:

## HAZARD INTENSITY LEVEL

There are three levels of hazard intensity identified by signal words -**WARNING**, **CAUTION**, and **FOR SAFETY**. The level of hazard intensity is determined by the following definitions:



**WARNING** - Hazards or unsafe practices CAN result in severe personal injury or death.



**CAUTION** - Hazards or unsafe practices which could result in minor personal injury or product or property damage.

**FOR SAFETY:** To identify actions which must be followed for safe operation of equipment.

Report machine damage or faulty operation immediately. Do not use the machine if it is not in proper operating condition. The following is information that signals some potentially dangerous conditions to the operator or the equipment. Read this information carefully. Know when these conditions can exist. Locate all safety devices on the machine. Please take the necessary steps to train the machine operating personnel.

### **FOR SAFETY:**

DO NOT OPERATE MACHINE:

- Unless trained and authorized.
- Unless Operation Guide is read and understood.
- In flammable or explosive areas.
- In areas with possible falling objects.

WHEN SERVICING MACHINE:

Avoid moving parts. Do not wear loose clothing, jackets, shirts, or sleeves when working on the machine. Use only manufacturer approved replacement parts.

## HYBRID GROUNDING INSTRUCTIONS 120V (when applicable)

THIS PRODUCT IS FOR COMMERCIAL USE ONLY

## ELECTRICAL:

In USA this machine operates on a 15 amp nominal 120V, 60 hz, A.C. power circuit. The amp, hertz, and voltage are listed on the data label found on each machine. Using voltages above or below those indicated on the data label will cause serious damage to the motors.

## GROUNDING INSTRUCTIONS:

This appliance must be grounded. If it should malfunction or break down, grounding provides a path of least resistance for electric current to reduce the risk of electric shock. This appliance is equipped with a cord that has an equipment-grounding conductor and grounding plug. The plug must be inserted into an appropriate outlet that is properly installed and grounded in accordance with all local codes and ordinances.

For use on a nominal 120 volt circuit with a grounded plug that looks like the plug in FIGURE A. A temporary adaptor that looks like the adaptor in FIGURE C may be used to connect this plug to a 2-pole receptacle as shown in FIGURE B, if a properly grounded outlet is not available. The temporary adaptor should be used only until a properly grounded outlet (FIGURE A) can be installed by a qualified electrician. The green colored rigid ear, lug or similar that extends from the adaptor must be connected to a permanent ground such as a properly grounded outlet box cover. Whenever the adaptor is used, it must be held in place by a metal screw.

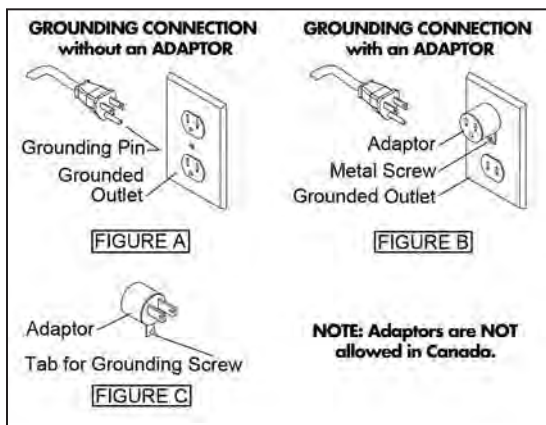

**WARNING**

Improper connection of the equipment-grounding conductor can result in electric shock. Check with a qualified electrician or service person if you are in doubt as to whether the outlet is properly grounded. Do not modify the plug provided with the appliance - if it will not fit the outlet, have a proper outlet installed by a qualified electrician.

## SAFETY LABEL LOCATION

If at any time the safety labels become illegible, contact your authorized representative for prompt replacement.

## TECHNICAL DETAILS

ITEM	SPECIFICATIONS
Motor	36 V/330W - DC, 3000 RPM, 59 dB with protective cover
Dual Speed	3000 RPM (Orbital), 120 RPM (Rotational)
Base Diameter	11" (27.9 cm)
Wheel Diameter	4" (10.16 cm)
Solution Tank Capacity	3/4 Gallon (2.84 L)
Pump	58 PSI (4 BAR)
Noise Level	59 dB
Height	47" (119 cm)
Weight	28 Lbs/12.7 Kg (+6 lbs/2.7kg w/tank & battery)
Battery (BMS)	Lithium-ion 36V/40W/6Ah (Battery Management System)
Run Time	Up to 45 Minutes (depending on floor type/pad)
Charge Time	90 Minutes





## Unpacking

Open shipping box (both sides). Remove packaging material and roll machine out of the box.

## Solution Tank

Disconnect the quick-connect fitting located at the bottom of the solution tank. Remove solution tank by pulling away from the handle frame. Add water or cleaning detergent of choice. Snap solution tank onto frame. Reconnect the quick-connect fitting.



## CAUTION

Ensure solution tank cap is securely fastened to avoid leaks and spills.

## Pads/Brushes

Choose an Orbot pad or brush of choice to clean or restore the desired floor.

Place under the hook pad driver BEFORE powering on machine.  
To remove, simply peel off.



## Power Switch

Turn power switch to the OFF position located at the top of the handle. The power switch will illuminate when powered ON.



## Battery

Insert the battery into the battery tray located inside the base housing cover.

Ensure to completely lock the battery into position until you hear a click sound.

To remove the battery, release the battery lever and pull out. You can use your right hand to help push the battery out of the tray.



## WARNING

Always remove battery and immediately charge to avoid damage.



# OPERATION

## Handle Position

Before powering ON the machine, lower the handle into a comfortable position by pulling out the pull-pin lever located on the lower left side of the handle fork.

## Operating Machine

Turn power switch on, and begin to maneuver the machine over the floor surface.

The machine can be moved in all directions.

When cleaning carpet, the machine is best moved forward to backwards, while spraying only forward.

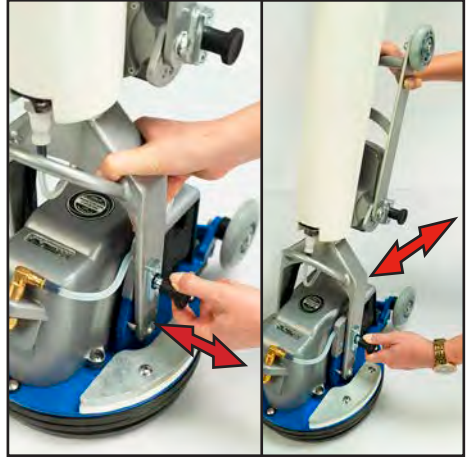

## Operating Option

To increase operator comfort, the wheel kit can be lowered down onto the floor by releasing the pull-pin lever and choosing the desired height.

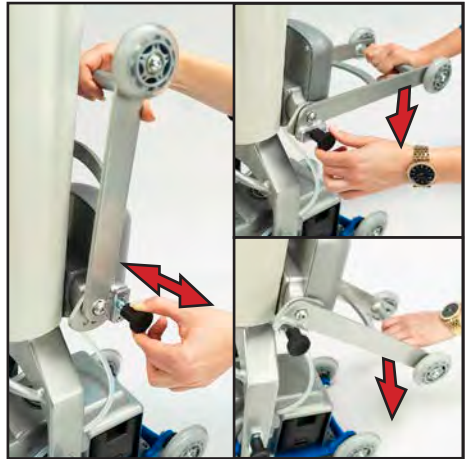

## Spray System

To apply water or detergent to the floor surface, press the spray switch located on the top right side of the handle.

## System Light Indicators (Located on Top of Motor Cover)

### Blue lights:

- One Blue Light: Low Battery Level
- Two Blue Lights: Medium Battery Level
- Three Blue Lights: Full Battery Level

### Red light:

- Machine is working over full load capacity. Run times will lessen.

### Green light:

- Machine is working under light load capacity. Run times will increase.



### Lifting & Handling

To lift the machine into a vehicle, use handle located on fork. To lift the machine up stairs, lower the wheel kit to 90 degrees.

### **CAUTION**

### Storage

Always keep machine stored in the upright position. Do not store brushes under pad driver when not in use.



## ACCESSORIES AND APPLICATIONS

### **WARNING**

Never store the accessories in wet conditions. Keep away from extreme heat and from chemicals.

### Pad Driver

To replace the pad driver, remove the 4 screws using a #3 Phillips/Star screwdriver. Using the incorrect screwdriver can result in stripping the screw head.

Pad drivers should be replaced when the hook material becomes clogged with excess lint and debris.

### **CAUTION**

It is important to operate the machine using clean pad drivers to ensure optimal cleaning performance. When excess clogging occurs from lint and debris, the hook tensile strength is reduced which leads to damaged pads and brushes.

### **WARNING**

Never place driver onto floor surface without a pad or brush.



## OPERATION

### SuperZorb Pad

Our exclusive SuperZorb pad is made of a special cotton and polyester blend. One of the primary components that help to extract an essential amount of soil from the carpet fibers. They also play an important role to achieve fast dry times. SuperZorb pads can be used on both sides. SuperZorb pads are machine washable. Allow to air dry.

SuperZorb pads are also great to be used to power mop hard floors.

### MicroFiber Pad

Use for cleaning all carpets and hard floors. Best used for high friction floor types. Choose over SuperZorb Pads when laundry machines are limited. Can be easily washed by hand.

### UltraLift Pad

The UL pads are used to remove stubborn stains and grease trapped in microporous hard floors such as tile, stone, VCT/vinyl, concrete, wood, epoxy, and more.

Use with water or mild detergents.

### AkwaStrip Pad

The AkwaStrip pad is a chemical free stripping pad made of a unique material filled with diamonds. Used for deep cleaning and to remove wax off of vinyl, VCT, linoleum, wood, safety tiles and more. Used on both sides. Thoroughly rinse with clean water after use.

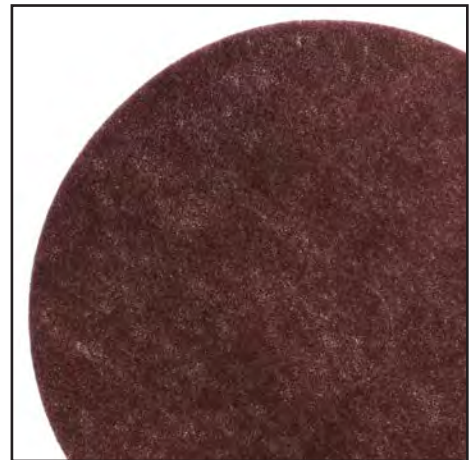

## StoneFlash Pads

StoneFlash pads are part of a 5 step system for grinding, honing and polishing marble, terrazzo, travertine, limestone and more.



## Carpet Brush

To lift carpet fiber piles.  
Use for extra scrubbing power to release stubborn stains.

Also use on hard or rubber floors to release dirt from small cracks, crevices, and pores.

### **!** CAUTION

Do not store brushes under the machine. As a result, bristles will become damaged and deformed.



## Tile & Grout Brush

Use for cleaning hard floor tiles, grout lines, pores, cracks, and crevices.

### **!** CAUTION

Do not store brushes under the machine. As a result, bristles will become damaged and deformed.



# MAINTENANCE

## COMMON MAINTENANCE

### Cleaning the Machine

- Always maintain a clean machine to preserve it's presence and optimal performance.
- Maintain clog free hook pad drivers to maximize cleaning performance and eliminate damage to pads and brushes.

### Checking the Machine

- Check counter weight bearing to ensure optimal performance and minimal vibration.
- Check for any loose nuts and bolts to minimize vibration.
- Check pull lever pins for any loose fasteners.
- Check solution tank filters to ensure maximum solution flow.

### SLiM Cleans in Small Spaces

- Ease of cleaning in tight and narrow spaces such as under chairs.
- Ease of cleaning within hard to reach spots in bathrooms.
- Ease of carrying up stairs as well as cleaning them.
- Also, planes, trains, automobiles, etc. are very hard to clean where the SLiM comes in handy to assist in these areas. Plus many more possible opportunities where most cleaning machines are too large to get to those small spaces.

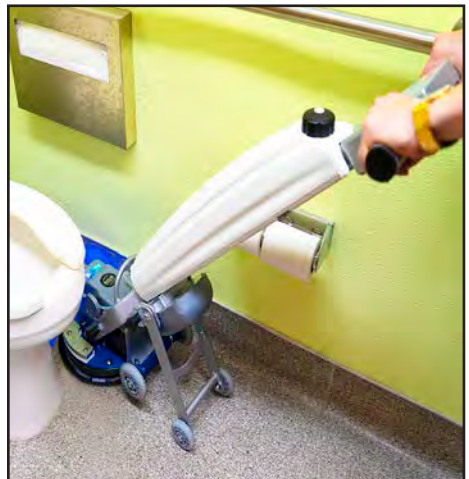
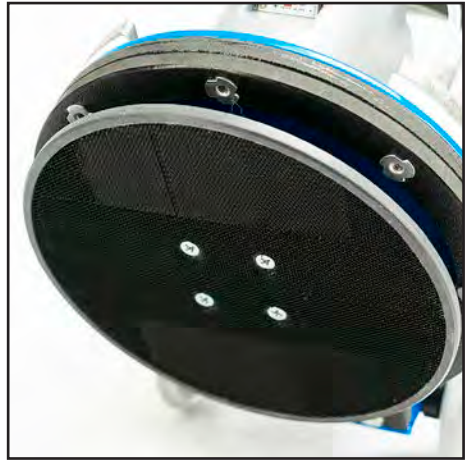

## SOLUTION TANK ASSEMBLY

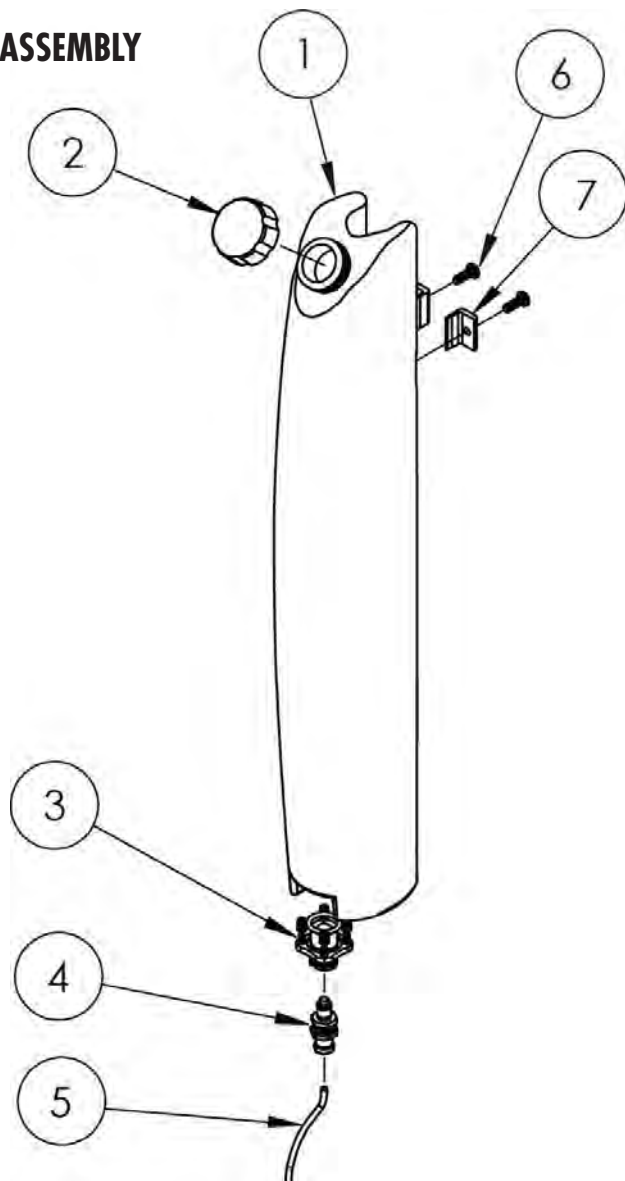

ITEM NO	PART NUMBER	DESCRIPTION	QTY.
1	01-221	SOLUTION TANK	1
2	01-222	FILL TANK	1
3	01-223	TANK FILTER ADAPTER ASSEMBLY	1
4	01-224	MALE QUICK-CONNECT	1
5	01-225	TANK SOLUTION HOSE	1
6	01-226	TANK TAB SCREW, 1/4"-20 X 3/4"	2
7	01-227	TANK TAB	2

# PARTS

## HANDLE / FRAME ASSEMBLY

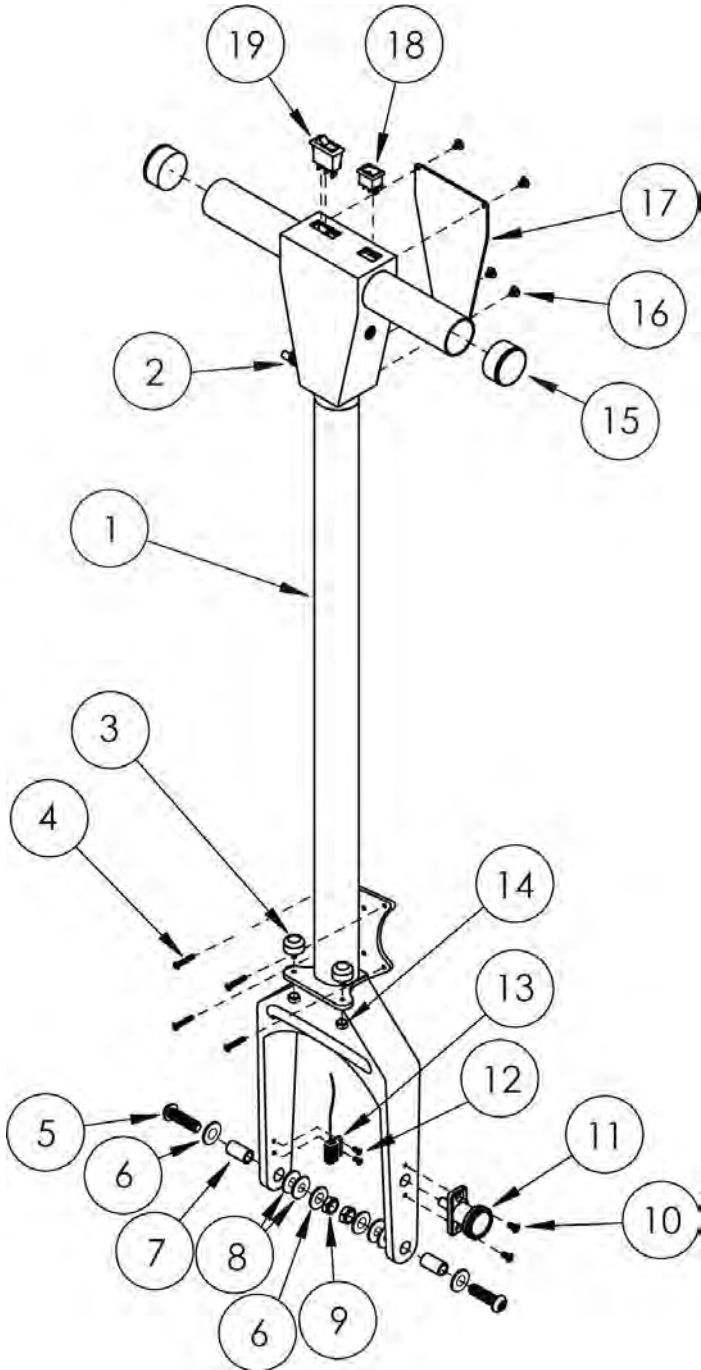



## HANDLE / FRAME ASSEMBLY

ITEM NO	PART NUMBER	DESCRIPTION	QTY.
1	01-201	WELDED ALUMINUM HANDLE ASSEMBLY	1
2	01-202	15 AMP CIRCUIT BREAKER	1
3	01-203	RUBBER, TANK MOUNT STOP	2
4	01-204	PUMP MOUNT SCREW 6-32 X 7/8"	4
5	01-205	HANDLE FORK MOUNTING SCREW, 3/8-16 X 1-3/8"	2
6	01-206	HANDLE FORK MOUNTING WASHER 3/8"	4
7	01-207	HANDLE FORK SPACER	2
8	01-208	HANDLE FORK INNER MOUNTING WASHER 1/2"	4
9	01-209	HANDLE FORK MOUNTING NUT 3/8"	2
10	01-210	PULL PIN MOUNTING SCREW 10-24 X 5/8"	2
11	01-211	PULL PIN	1
12	01-212	REED SWITCH, MAGNET, SCREW, 6-32 X 5/8"	2
13	01-213	REED SWITCH, MAGNET	1
14	01-214	RUBBER, TANK MOUNT STOP, NUT, 8-32	2
15	01-215	PLASTIC CAPS, TUBE	2
16	01-216	TERMINAL BOX COVER SCREW, 8-32 X 3/16"	4
17	01-217	TERMINAL BOX COVER	1
18	01-218	SPRAYER SWITCH	1
19	01-219	POWER SWITCH	1

# PARTS

## WHEEL KIT / PUMP ASSEMBLY

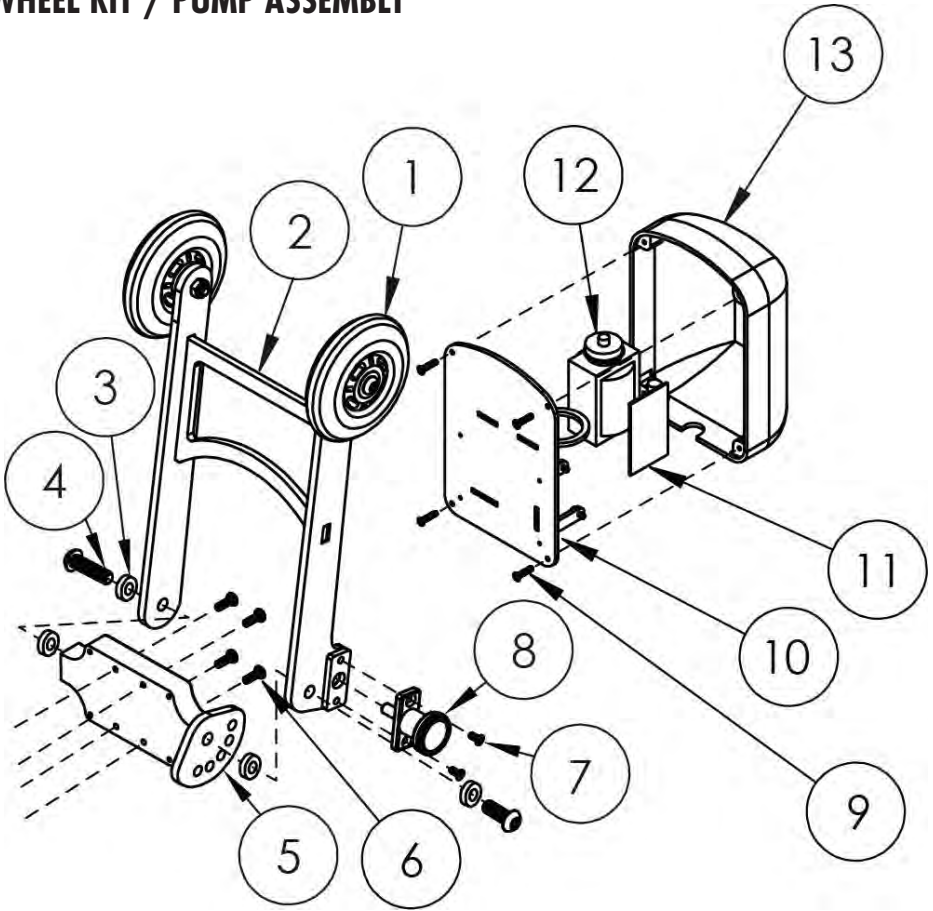

ITEM NO	PART NUMBER	DESCRIPTION	QTY.
1	02-221	WHEEL, 3"	2
2	02-222	ALUMINUM WHEEL KIT FRAME	1
3	02-223	WHEEL KIT WASHER, NYLON, 3/8" ID X 3/4" OD	4
4	02-224	WHEEL KIT MOUNTING SCREW, 3/8"-16 X 1"	2
5	02-225	WHEEL KIT MOUNT	1
6	02-226	WHEEL KIT MOUNT SCREW, 10-24 X 5/8"	4
7	02-227	PULL PIN MOUNTING SCREW, 10-24 X 5/8"	2
8	02-228	PULL PIN	1
9	02-229	PUMP COVER SCREW 6-32 X 5/8"	4
10	02-230	PUMP MOUNT	1
11	02-231	PUMP CIRCUIT BOARD	1
12	02-232	PUMP 58 PSI / 4 BAR	1
13	02-233	PUMP COVER	1

## SPRAY NOZZLE & MOTOR COVER ASSEMBLY

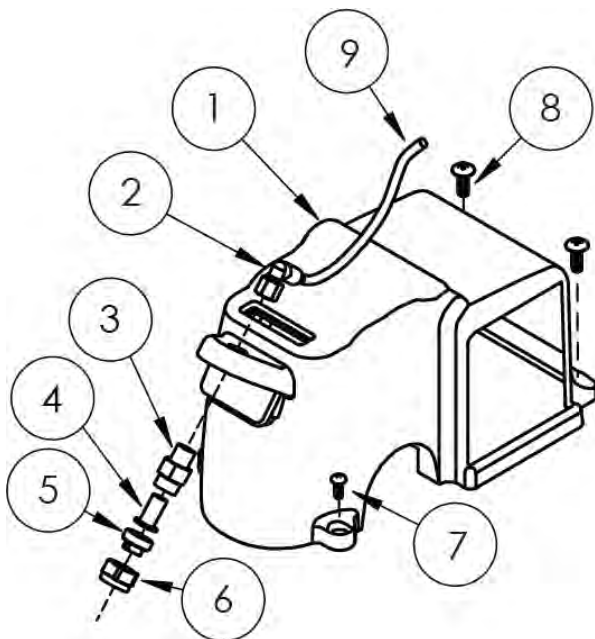

ITEM NO	PART NUMBER	DESCRIPTION	QTY.
1	03-201	MOTOR COVER, SILVER	1
2	03-202	90° QUICK-CONNECT SPRAY FITTING	1
3	03-203	SPRAY JET BODY	1
4	03-204	CHECK VALVE STRAINER	1
5	03-205	SPRAY JET TIP	1
6	03-206	SPRAY JET CAP	1
7	03-207	FRONT MOTOR COVER MOUNTING SCREW, 1/4-20 X 5/8"	2
8	03-208	REAR MOTOR COVER MOUNTING SCREW, 1/4-20 X 1"	2
9	03-209	SPRAYER HOSE	1

## BATTERY ASSEMBLY

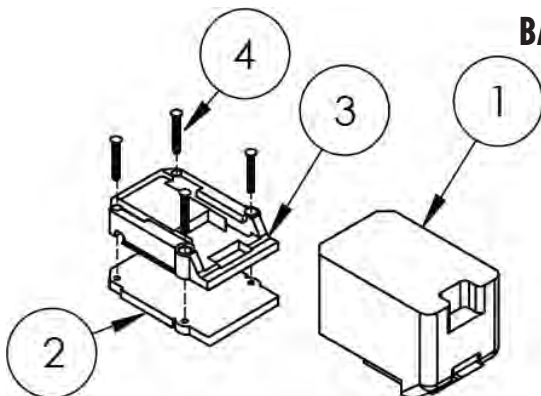

ITEM NO	PART NUMBER	DESCRIPTION	QTY.
1	03-211	BATTERY, 36V, 6AH	1
2	03-212	BATTERY FOAM BASE	1
3	03-213	BATTERY TRAY	1
4	03-214	BATTERY TRAY MOUNTING SCREW, 10-32 X 1-1/2"	4

## PARTS

### BASE & DRIVER PLATE ASSEMBLY

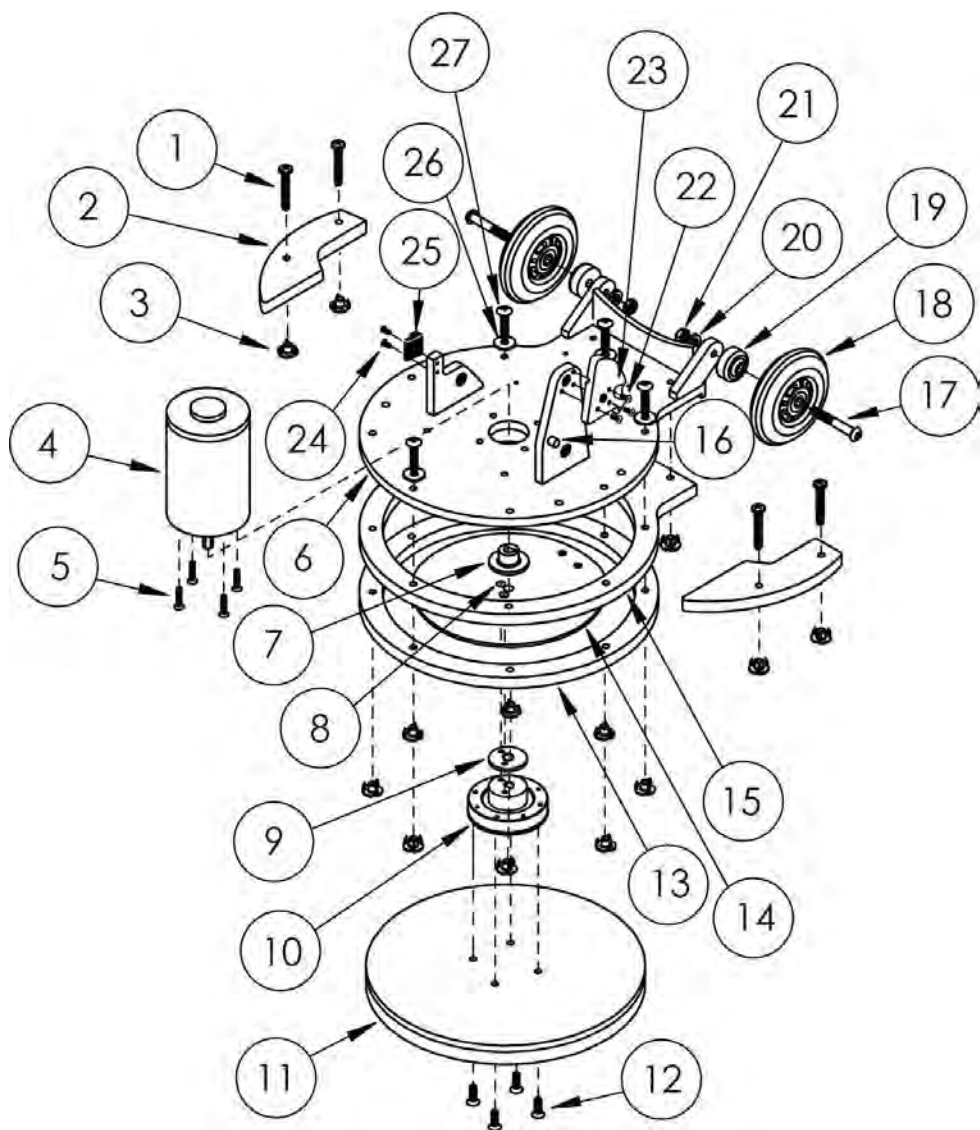

## BASE & DRIVER PLATE ASSEMBLY

ITEM NO	PART NUMBER	DESCRIPTION	QTY.
1	03-221	WEIGHT KIT MOUNTING SCREW, 1/4-20 X 1-1/4"	4
2	03-222	WEIGHT PLATE	2
3	03-223	BUMPER THREADED INSERT	16
4	03-224	MOTOR, 36V / 330W, 3000 RPM, 59DB	1
5	03-225	MOTOR MOUNTING SCREW, 10-32 X 3/4"	4
6	03-226	BASE PLATE	1
7	03-227	SHAFT SUPPORT	1
8	03-228	BEARING ASSEMBLY MOUNTING SCREW, 1/4-20 X 3/4"	2
9	03-229	BEARING ASSEMBLY WASHER	1
10	03-230	BEARING ASSEMBLY	1
11	03-231	DRIVER ASSEMBLY	1
12	03-232	DRIVER MOUNTING SCREWS, 1/4-20 X 1"	4
13	03-233	LOWER BUMPER RING	1
14	03-234	COUNTER WEIGHT PLATE	1
15	03-235	UPPER BUMPER RING	1
16	03-236	EAR STOPPER PIN	1
17	03-237	WHEEL MOUNTING SCREW, 5/16" X 2-1/4"	2
18	03-238	WHEEL, 4"	2
19	03-239	WHEEL SPACER	2
20	03-240	WHEEL MOUNTING WASHER, 5/16" X 5/8"	2
21	03-241	WHEEL MOUNTING LOCK NUT, 5/16"	2
22	03-242	PULL PIN SLIDE MOUNTING SCREW, 10-24 X 3/8"	3
23	03-243	PULL PIN SLIDE	1
24	03-244	REED SWITCH, MAGNET MOUNTING SCREW, 6-32 X 3/8"	2
25	03-245	REED SWITCH, MAGNET	1
26	03-246	BASE MOUNTING WASHER, .281 OD, .734 X 1/16"	4
27	03-247	BASE MOUNTING SCREW, 1/4-20 X 1-1/2"	4

**PARTS**

**COMPLETE ASSEMBLY**

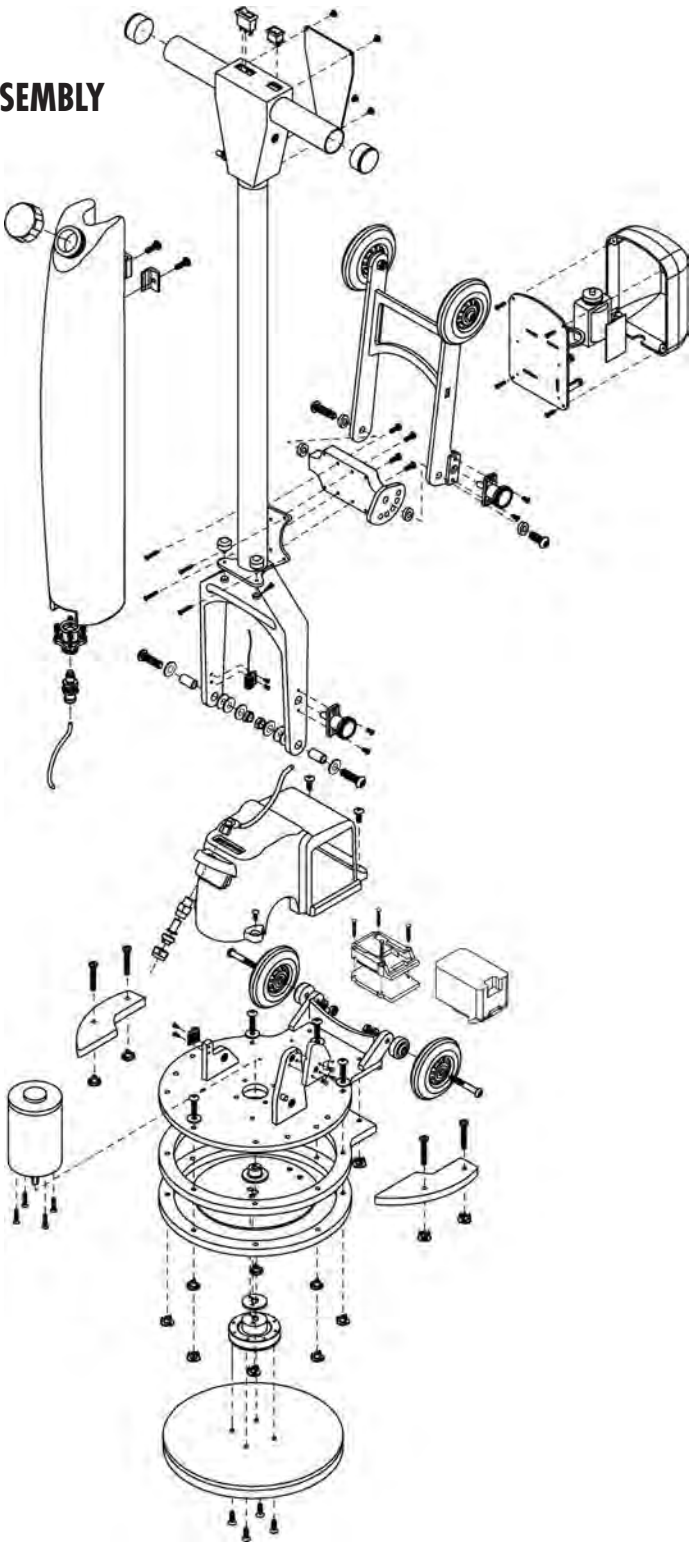

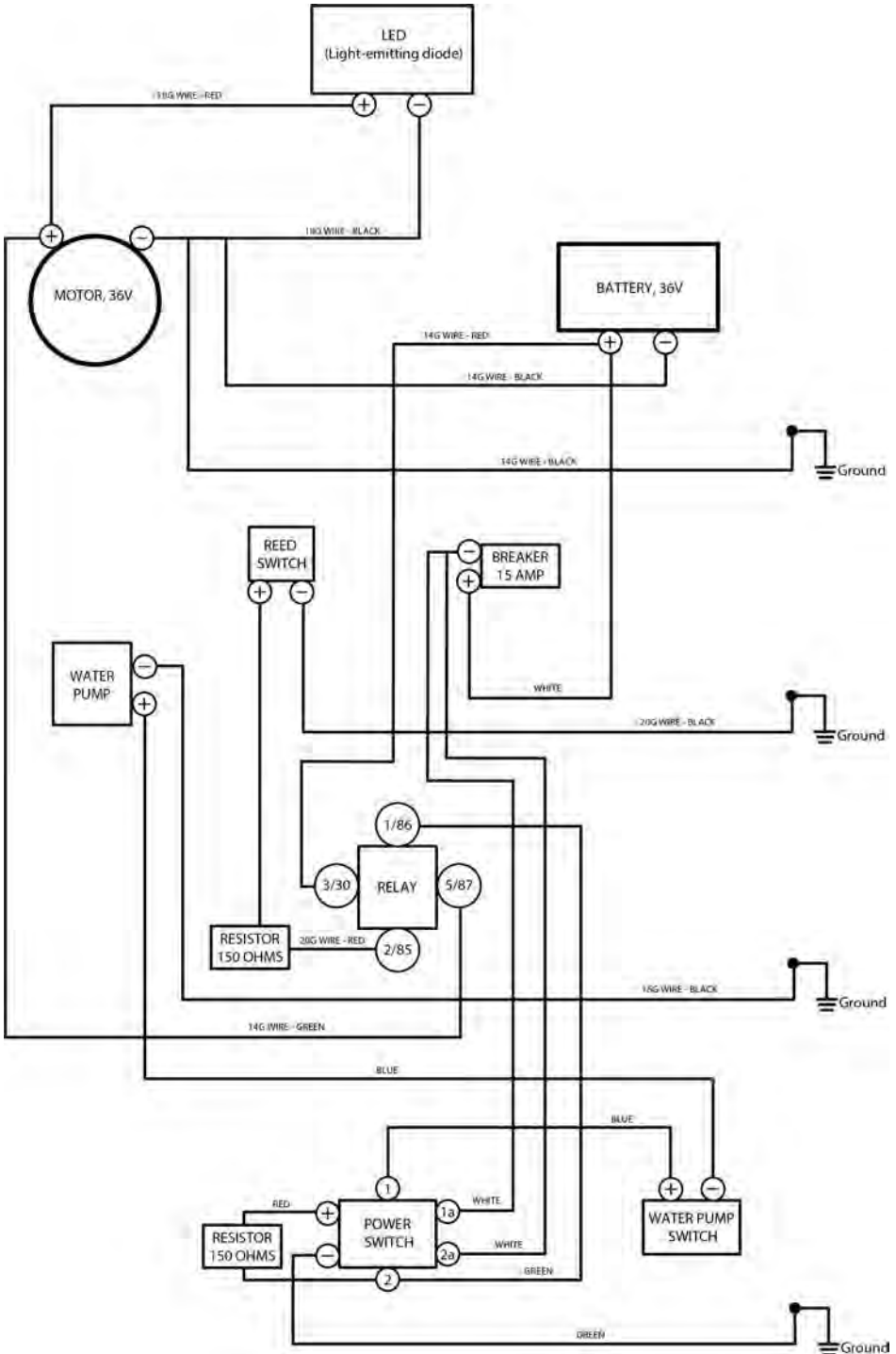

*“Innovators in Orbital Floor Care”*

**ORBOT<sup>®</sup>**

3275 Corporate View, Vista, CA 92081, USA

P: 760-936-8054 | [CustomerService@orbotusa.com](mailto:CustomerService@orbotusa.com)

[www.orbotusa.com](http://www.orbotusa.com)

**EXPERIENCE THE NEW METHOD to CLEAN ANY FLOOR!**

